

Maintenance and Operating Instructions

ProAir

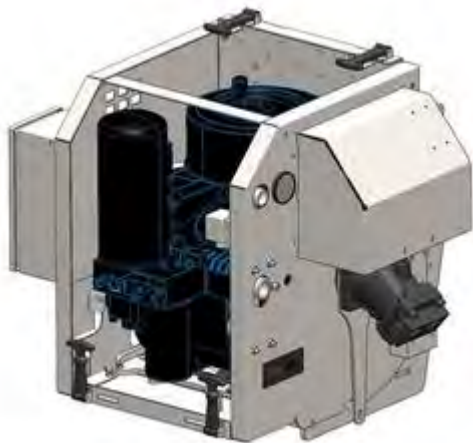

Introduction

Dear customer,

Congratulations on the purchase of the tire pressure control system **ProAir** produced by **AgrarPro**. In order to maintain of the equipment and to ensure a long lifetime, carefully read this manual and submit it to new personnel to be trained as well. Damages arising from inobservance of the instructions, insufficient maintenance or improper handling, are not covered by warranty.

CAUTION! Read before Putting into Operation !

Table of Contents

1. Intended Use	5
2. General Safety Information.....	5
3. Product Description	6
4. Installation	6
4.1. Mounting Configuration	7
4.2. Hydraulic System	7
4.2.1. Characteristic Values of Oil Supply	7
5. Maintenance.....	8
5.1. Opening the ProAir Equipment.....	8
6. Start-up of the Compressor	9
6.1. Initial Start-up	9
6.1.1. Rotational Direction Check.....	9
6.1.2. Test Run	10
6.2. Restart of the Screw-type Compressor Unit	10
7. Maintenance of the Compressor	11
7.1. Safety Notes.....	11
7.2. Oil Level	12
7.2.1. Inspection Interval	12
7.2.2. Procedure.....	12
7.3. Oil Change	13
7.3.1. Interval	13
7.3.2. Oil Drain	13

7.3.3.	Oil Filling	14
7.3.4.	Oil Recommendation.....	15
7.4.	Oil Filter.....	16
7.4.1.	Change Interval.....	16
7.4.2.	Procedure.....	16
7.5.	Fine Separator Cartridge.....	17
7.5.1.	Change Interval.....	17
7.5.2.	Procedure.....	17
7.6.	Air Filter.....	18
7.6.1.	Change Interval.....	18
7.6.2.	Procedure.....	18
7.7.	Cooler.....	19
8.	Control.....	20
8.1.	Introduction	20
8.2.	Switching ON/OFF	21
8.3.	Operating Modes.....	21
8.3.1.	Display Mode	21
8.3.2.	Field Mode	22
8.3.3.	Road Mode.....	23
8.4.	Menu	23
8.4.1.	Submenu ‚Computer‘	24
8.4.2.	Submenu ProAir	25
8.4.3.	Submenu ‚Display‘	26
8.5.	Error Messages	27
8.5.1.	Compressor Temperature	27
8.5.2.	CAN Error.....	28
8.6.	IFM-Display – Control Loop Settings.....	28
8.6.1.	1st Control Loop.....	28
8.6.2.	2nd Control Loop.....	29
8.6.3.	3rd Control Loop.....	29
8.7.	Connection Plans	31
8.7.1.	Pinout CR0403 as from 06/27/2016.....	31
8.7.2.	Pinout OPUS A3	32
9	Spare Parts NK 60.....	33

9.1	Case	33
8.6.	Compressor/Control	36
10.	Spare Parts EVO 3	38
10.1	Case	38
10.2	Compressor/Control	41
11.	Spare Parts EVO6	43
11.1	Case	43
11.2	Compressor/Control	46
12.	Imprint	48
13.	Appendix	49

1. Intended Use

The tire pressure control system has been designed for agricultural applications. It is used to provide for different pressure values for field and road travel. For that purpose, corresponding modes of operation can be selected to choose the settings.

The type plate should not be modified or removed, as it shows important information for the manufacturer. In case of inobservance, the warranty is declared null and void.

2. General Safety Information

Every user should be aware of the fact that negligence with respect to safety instructions may give rise to material damage and injuries.



Never hand over the equipment to persons unable to understand or to follow safety instructions.



Before start up, users should familiarize themselves with the function of service elements and devices (refer to chapter "Control").



Instructions of the vehicle to which the **ProAir** equipment is installed, should be followed likewise.



The admissible pressure range for set values is from 0.8 to 4.0 bar.



Observe safety information of attached labels.



The equipment should not be operated in road traffic. Before driving on public roads subject to traffic regulations, disable the unit by means of the main switch and close stop-cock at each tire.



Do not switch off the device by means of the main switch, before tires have reached the preset value, e.g. before tire inflation has been completed.

Before maintenance and service work:

Never forget to switch off the motor of the tractor (respectively of the vehicle in question). No hydraulic pressure should be applied to the **ProAir** device!



Before opening the case, uncouple the system from power source. Electrical connection should be reestablished only when the case has been closed.

After operation, some of the components may still be hot, so act carefully.

3. Product Description

The **ProAir** unit features a rugged metal case with integrated compressor, an oil engine acting as drive of the compressor and an oil cooler. By means of an oil line driving the motor, compressed air is produced by means of the compressor and finally supplied to the tires via control unit; this way the desired tire pressures are established. Pressure values are set up by OpusA3- or IFM-Display.

4. Installation

When coupling the unit to a vehicle, easy access for purposes of maintenance must be provided. Comply to the safety regulations of the vehicle as well.

Sufficient aeration of the oil cooler is important.

4.1. Mounting Configuration

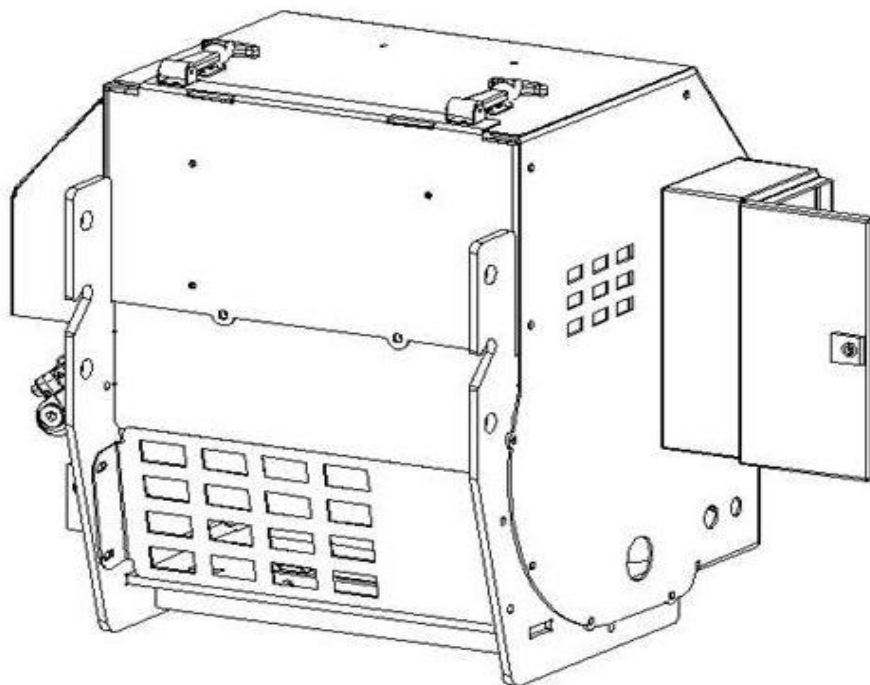

For at least to four of the eight mounting positions, screws or bolts must be used (evenly distributed) for safe connection. Other methods of attachment are not admissible – resulting damages are not covered by warranty.

4.2. Hydraulic System

Use a hydraulic valve to switch the **ProAir** device to central float position.
NK 60 systems feature a Danfoss oil engine (QXM32-016).
For EVO3 systems, oil engine Hydroeduc M12 is used.
For EVO6 systems, Hydroeduc M25 is relevant.

4.2.1. Characteristic Values of Oil Supply

NK 60 Maximum pressure 200bar
Maximum volume flow: 70-95 l/min

Maximum pressure: 200 bar
EVO 6 → 150l/min → 6000rpm
EVO 3 → 73l/min → 6000rpm
5000-6000 rpm compressor = optimum speed range

5. Maintenance



Caution!

Chapter “General Safety Information“ is basic for every maintenance procedure!



Caution!

Never use compressed air or high-pressure cleaners for cleaning purposes.

Before each use, check the oil cooler for dirt and damages. In case of need, correct the situation immediately.

Refer to maintenance instructions of screw-type compressor NK series (BAUER / Rotorcomp) as well!

5.1. Opening the **ProAir** Equipment

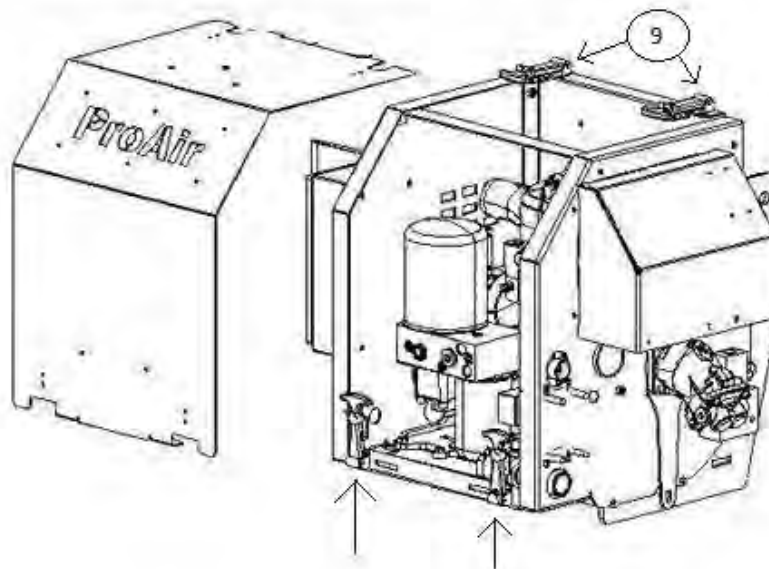

1. In order to prevent unexpected start, disconnect the equipment from the power source.
2. Detach the four hood retainers, remove the cover (Pos. 9), and keep the items in a safe place.
3. Carry out the intended work.
4. Reinstall the cover.
5. The equipment is ready to be used again.

6. Start-up of the Compressor

All components of the screw-type compressor have been inspected and tested by the manufacturer, so that power and control data are met. During the first hours of operation, the compressor unit should be monitored all the same.

6.1. Initial Start-up

The following points are essential for initial start-up:

- Correct direction of rotation must be ensured. (Refer to chapter 6.1.1 "Rotational direction check").
- The final pressure specified on the type plate should not be exceeded.
- Screw-type compressor units running under load should not be switched off by emergency or main switch.
- Oil level check (Refer to chapter 8.2 "Oil level")
- Before each initial start-up or start-up after longer standstill of the screw compressor compact module, always carry out measures described in chapter 7.2 "Restart of screw-type compressor unit".
- Verify stop cock position.
- Firm seat of all screwings and fastening screws is mandatory.

6.1.1. Rotational Direction Check

Direction of rotation: Standard version, viewing to the shaft left-hand (counter clockwise).

Caution!



- During initial start-up with hydraulic system, as well as after modifications concerning the electric supply of the electric engine, check the direction of rotation of the screw-type compressor. For this purpose, briefly switch ON the drive engine and directly disable it again.
 - Wrong direction of rotation for more than 2 seconds gives rise to destruction of the compressor.
-

6.1.2. Test Run

Caution!



Whenever the system is unpressurized very quickly in Stop Mode with stop cock opened, until opening pressure of minimum pressure valve is reached, this kind of procedure may entail foaming of the oil inside the separating tank.

Possible consequences:

- Together with discharge air, oil escapes from the system.
- Oil overfilling of fine separator cartridges.
- Presence of oil in compressed air during restart of the system.

For this reason, during test run observe the following:

- The system should be switched OFF only with stop cock closed.
- If possible, connect the system to a compressed air chamber!

6.2. *Restart of the Screw-type Compressor Unit*

After longer standstill (ca. three months), prior to restart, the following measures are required:

- Turn the compressor several times by hand, meanwhile observing the correct sense of rotation.
- With the compressor unit always standing still, use a syringe to insert a quantity of 0.2 l oil into the oil aspiration boring (type must be identical with the oil in the separator tank).
- Again, turn compressor several times by hand (observing correct direction).
- Check the oil level in the separator tank, refill in case of need (refer to chapter 7 "Maintenance").
- Inspect the run of the compressor unit for at least 15 minutes.



Warning!

The unit should not be started with the conveying chamber completely filled up. Risk of severe damages!

7. Maintenance of the Compressor



Act carefully
RISK OF ACCIDENTS!

7.1. Safety Notes

After start-up, the client himself is responsible for correctly equipping and installing the system.

- For maintenance and repair, exclusively proper tools in correct state should be used.
- Always make use of original spare parts.
- Before maintenance and repair, the system should be switched OFF and disconnected from mains. Restart by mistake should be prevented.
- Never attempt to dismantle parts being under pressure. First remove all pressure sources, and perform pressure relief for the entire system.
- For purposes of cleaning, flammable solvents or carbon tetrachloride are not admissible. Formation of toxic vapors meanwhile, must be prevented.
- During maintenance and repair, a clean environment is essential. No dirt should penetrate into the system. Parts and uncovered openings should be protected by clean rag, paper or tape.
- In the vicinity of the oil system, welding operation or other procedures generating excessive heat, are forbidden.
- No tools, loose parts or rags should be forgotten inside or on the system.
- After maintenance and repair, first check operational pressures, temperatures, timers and oil level before restarting. Proper function of controls and switch OFF devices must be ensured.
- Electric components and controls must be protected from contact with humidity (rain, steam jet etc.).

7.2. Oil Level

7.2.1. Inspection Interval

For the compressor, regular inspection of the oil level is mandatory, refill in case of need.

- Once before start-up
- Afterwards, every 100 operating hours

7.2.2. Procedure

CAUTION!



- Parts of the system, oil and oil filler plug may still be hot (>80°C). **RISK OF BURNS!**
- Wear personal protective equipment!
- In case of hot oil, the level in unpressurized state may exceed the height in cold state by 10 mm. For this reason, open the filling screw slowly, otherwise oil may escape. If this happens, close the plug again without delay, and remove spilled oil as prescribed.

The screw plug of the oil filler neck features a lateral safety bore, through which some oil or air may escape, if residual pressure in the separator tank is still present. In this case, wait a moment before continuing.

- Switch OFF the system, unintentional restart should be prevented.
- Wait one minute before continuing.
- Remove screw plug (pos. 1) by hand, in unpressurized state.
- Check oil level.
- In case of need, refill oil (same type and trademark) up to the MAX level.
- Firmly reinstall screw plug (pos. 1) by hand.
- Restart the system.
- Leak tightness of the filling plug must be ensured. In case of need, exchange O-ring.
- Excess (spilled) oil must be removed carefully. Dispose of the oil according to the environmental legislation.

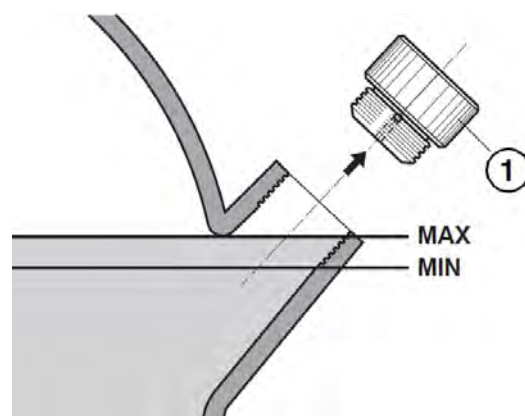

7.3. Oil Change

Caution!



- Rotating, pressurized and hot components.
RISK OF INJURIES!
- Oil change is admissible only in standstill and after total pressure relief of the compressor unit.

7.3.1. Interval

For the compressor, oil should be changed **every 250 to 300 operating hours, at least once per year.**

7.3.2. Oil Drain

For oil drain, the system should be at operating temperature.

- Switch OFF the compressor and remove the main switch to prevent unintentional restart.
- The compressor must be completely unpressurized.
- Slowly unscrew the screw plug of the oil filler neck.
- Carefully unscrew drain plug (pos. 1); collect waste oil in a convenient container.
- Clean the drain plug (pos. 1), insert a new seal ring and attach the plug again.

Dispose of the waste oil in conformity with environmental legislation!

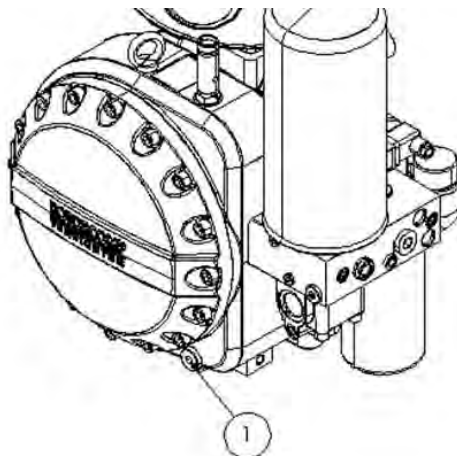

7.3.3. Oil Filling

- We recommend machine oil SAE30 CS 100.



Caution!

- Refill oil of same type and trademark, ca. 5 L (NK60 / EVO3); ca.9 L EVO 6
Observe oil recommendation in chapter 7.3.4.
- If the customer prefers making use of another oil type, the compressor module may have to be rinsed.

In the course of oil change, it is advisable to exchange oil filter and air filter simultaneously.

- Exchange oil filter, if required (pos 1).
- Refill up to the MAX level into the filler neck of the separator tank, and firmly screw in screw plug (pos. 2) by hand onto the filler neck.
- Switch ON the compressor, keep it running for ca. three minutes.
- Oil level check:
Fill in missing amount of oil once more up to MAX level.

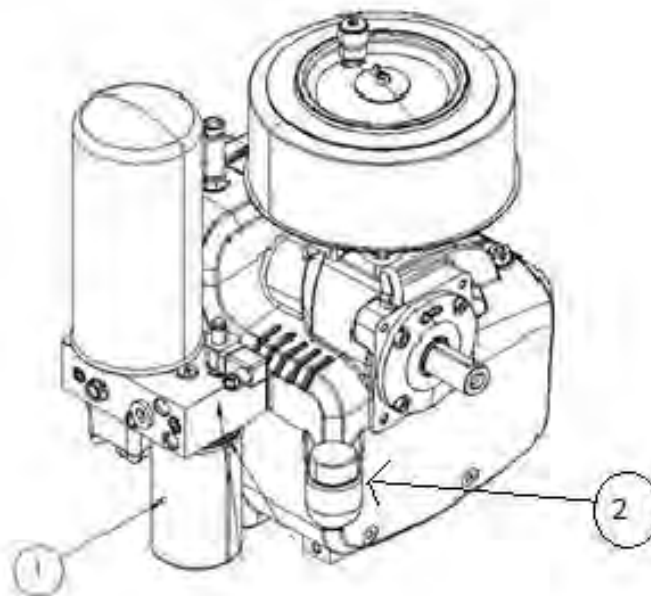

7.3.4. Oil Recommendation



Caution!

Never mix different oil types.

Oil used for screw-type compressors must meet the requirements of the particular application. The type of oil must be approved by the manufacturer for screw-type compressors and withstand also unfavorable operating conditions like contamination of intake air by gas, solvent vapor or exhaust gases, resp. high ambient temperature.

For screw-type compressors, in principle mineral oils, synthetic oils and biodegradable oils may be used.

With respect to the cooling oil inside the screw-type compressors, the following conditions must be met:

- High ageing resistance
- High dispersibility
- Combustion point: Above 200°C / 392°F
- Minimum foaming
- High corrosion protection
- Operating temperature up to 110°C / 230°F

Recommended oil type: Machine oil SAE 30 CS100

7.4. Oil Filter

7.4.1. Change Interval

Oil filters of screw-type compressors should be replaced **every 250 to 300 operating hours, at least once per year or during each oil change.**

7.4.2. Procedure

- Switch OFF the unit and wait, until it is completely unpressurized.
- Use a convenient tool to detach the oil filter cartridge (pos. 1).
- Grease the seal (pos. 2) of the new cartridge (pos. 1) by means of the same oil type (used also in the compressor module).
- With cartridge in vertical orientation, fill in the same oil type (used also in the compressor module), before screwing it in.
- Now attach the new cartridge to the separator head (pos. 3), and tighten it by hand.
- Switch ON the compressor unit again.
- In the course of operation, leak tightness of the oil filter must be verified.
- Check oil level, and refill up to the MAX level, if required.

Dispose of the used cartridge in conformity with environmental legislation!

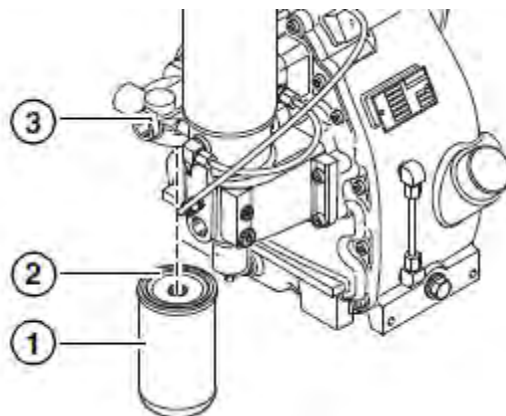

7.5. Fine Separator Cartridge

7.5.1. Change Interval

Oil filters of screw-type compressors should be replaced **every 500 to 1000 operating hours, at least once per year.**

In the case of excessively contaminated intake air or insufficient oil quality, this interval may have to be shortened.

7.5.2. Procedure

- Use a convenient tool, e.g. an oil filter strap spanner, to unscrew the fine separator cartridge (pos. 1).
- Grease the seal of the new cartridge (pos. 1) by means of the same oil type (used also in the compressor module).
- Tighten the new cartridge by hand. No tool required.
- Switch ON the compressor unit again.
- With the system running, leak tightness of the fine separator must be verified.

Dispose of the used cartridge in conformity with environmental legislation!

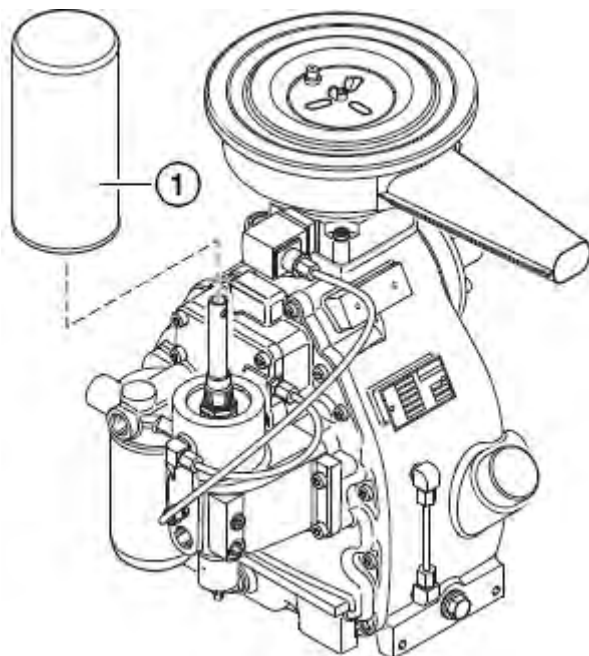

7.6. Air Filter

In the case of excessively contaminated intake air, the air filter should be inspected daily, otherwise an interval of 100 operating hours is sufficient. Whenever strong contamination becomes obvious, it must be replaced.

7.6.1. Change Interval

Air filters of screw-type compressors should be replaced **every 500 to 1000 operating hours, at least once per year.**

In the case of excessively contaminated intake air, this interval may have to be shortened.

7.6.2. Procedure



Caution!

- During exchange, no foreign matter (dust or dirt) should penetrate through the air inlet.

-
- Switch OFF the system protect it from unintentional restart.
 - Unscrew wing nut (Pos. 1) and detach filter cover (Pos. 2).
 - Dust present in the filter case must thoroughly be removed.
 - Take off the old filter element (Pos. 3).
 - Insert new element into the case.
 - Reinstall filter cover, while maintaining the correct orientation.
 - Tighten wing nut.
 - Switch ON the compressor unit again.
 - Test run and functional check.

Dispose of the used element in conformity with environmental legislation!

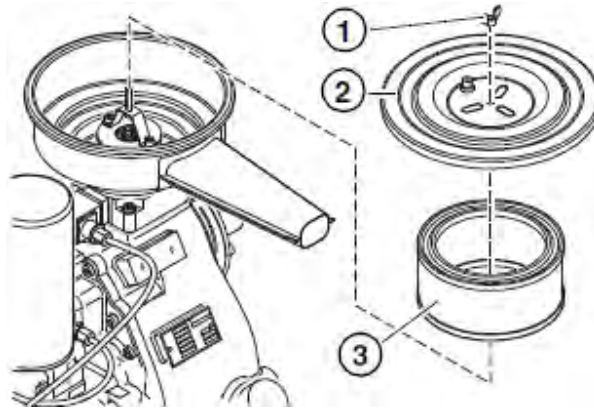

7.7. Cooler

Inspect the cooler **daily**, clean it **case of need**, at least once per year.



Caution!

- Carefully clean the cooler by means of a high-pressure cleaner. The procedure takes place with fan-shaped jet at low pressure (max. 20 bar).

8. Control



The equipment should not be operated in road traffic. Before driving on public roads subject to traffic regulations, disable the unit by means of the main switch and close stop-cock at each tire.

8.1. Introduction

The system is operated by means of the OPUS A3 or the IFM-Display.



Designation of buttons:

<F1> ... <F8>	Keys F1 to F8	A1	Settings
<ESC>	ESC Key	A2+A6	Options
<H>	HOME Key	A3	Menu Key
<C>	NEXT Key	A4	Field Mode
		A5	Road Mode

8.2. Switching ON/OFF

The display features the main switch used to activate and to disable the control.

After switching ON, the ‚Display‘ mode is opened, described below.

After switching OFF, all valves are closed. As the hydraulic valve is concerned as well, the compressor this way is disabled.



Do not switch off the device by means of the main switch, before tires have reached the preset value, i.e. before the control procedure has been completed.

8.3. Operating Modes

8.3.1. Display Mode

‚Display‘ mode is automatically enabled after system start. None of the both fields in the lower section at the right of the screen is illuminated in orange. Control automatics are not yet active, all valves are closed.

Absence of pressure control procedure for more than 30 seconds automatically reestablishes this mode.

The current measuring value of tire pressure appears in the left half of the screen. The center shows an illustration with the same value together with stored set values for two operating modes (**S**: Road, **F**: Field);

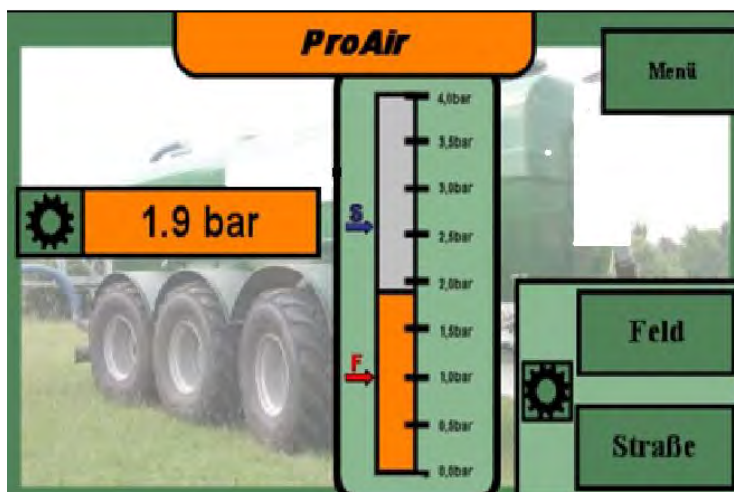

Use **<F7>** respectively **<F8>** buttons to toggle between the operating modes. The current mode is illuminated, showing the state of the system. Return to ‚Display‘ mode by pressing the same button again.

<F5> grants access to the menu to adapt system parameters according to the requirements.



Active tire pressure control is admissible only with stop cocks for all tires opened; otherwise the system may be damaged.

8.3.2. Field Mode

Illuminated Field button shows that this mode has been enabled. Control automatics are active, adapting the pressure to the selected set value.

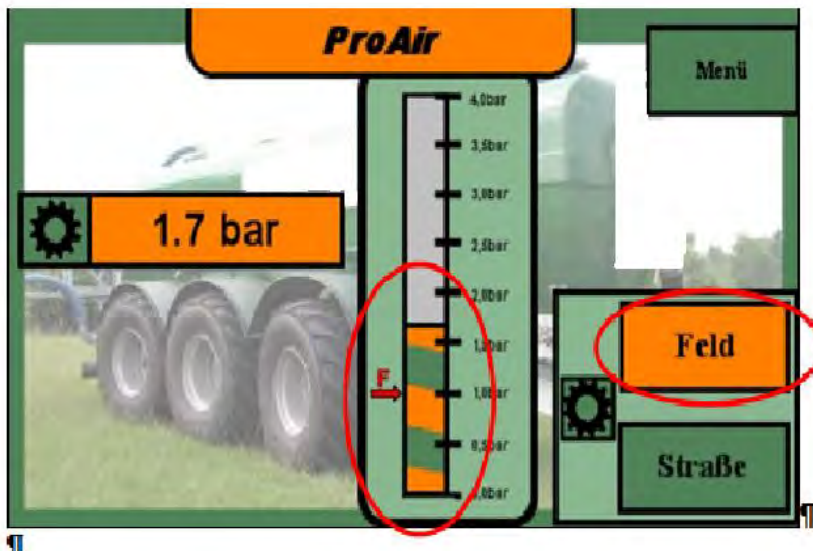

The set value for Field Mode is clearly visualized in the illustration in the center of the screen (F for „Field“). A moving bar shows that the system is currently adapting the pressure: Rising motion signifies active compressor and increasing pressure; in the case of descending direction, the pressure release valve has been opened and pressure decreased.

As soon as set pressure has been obtained, all valves are closed and the bar is shown homogeneously in orange.

8.3.3. Road Mode

Illuminated button 'Straße' shows that the Road mode has been enabled. Control automatics are active, adapting the pressure to the selected set value.

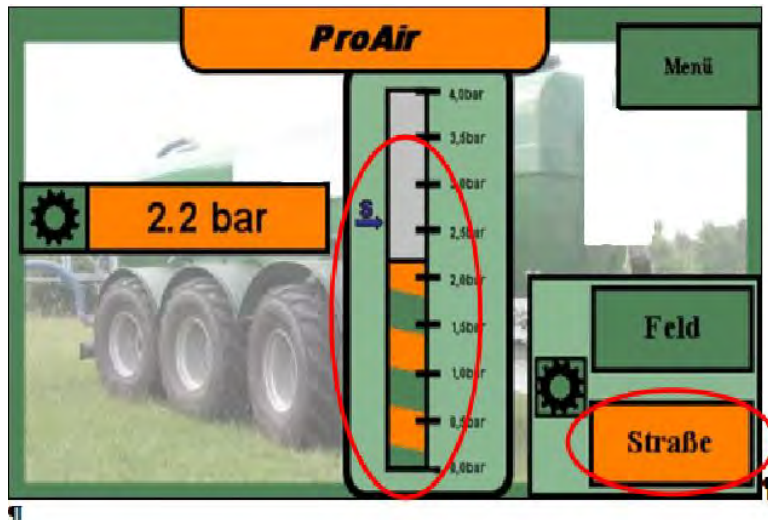

In principle, this mode is used identically to the „Field“ mode described above in chapter 8.3.2.

8.4. Menu

Three submenus are provided by the Menu function: **Rechner** (internal computer), **ProAir** and **Display**.



The internal computer is used for calculation of output power and accessible by **<F5>**. **<F6>** grants access to the parameters of **ProAir** tire pressure control, **<F8>** opens display settings.

Submenus appear in the left section of the screen and can be closed by pressing **<ESC>**. The currently active menu is illuminated. To close the Menu function and return to initial screen, press **<HOME>** from the corresponding submenu.

8.4.1. Submenu ‚Computer‘

The integrated computer represents a useful tool to calculate the output power taking into consideration input values „Travel“, „Working Width“ and „Drum Content“.

To change one of these values, select it by buttons **<F1>** to **<F3>**. The active parameter is illuminated, and the corresponding value starts flashing. Modification takes place by the rotary encoder located on the display (to increase: clockwise, lowering: counterclockwise). The new setting is stored by pressing rotary encoder or pressing the button of the current selection again.

Change of travel is carried out number by number. Pressing the encoder causes the digit to jump one step further.



Close the submenu by **<ESC>**.

8.4.2. Submenu **ProAir**

The set pressures for the two controlling operating modes are provided in the „**ProAir**“ submenu. Identically to the „Rechner“ submenu, activate the selected value by **<F2>** respectively **<F3>**, then it can be modified by rotary encoder. For reasons of safety, the accessible range is restricted to **0.8 to 4.0 bar**, otherwise the vehicle could be damaged.



Close the submenu by pressing **<ESC>**.

8.4.3. Submenu 'Display'

Settings provided in the „Display“ submenu relate to the presentation on the screen (brightness of display, brightness of buttons and selected language). Modification takes place as described for the other submenus.

Use <F3> and <F4> buttons to toggle between languages German and English.

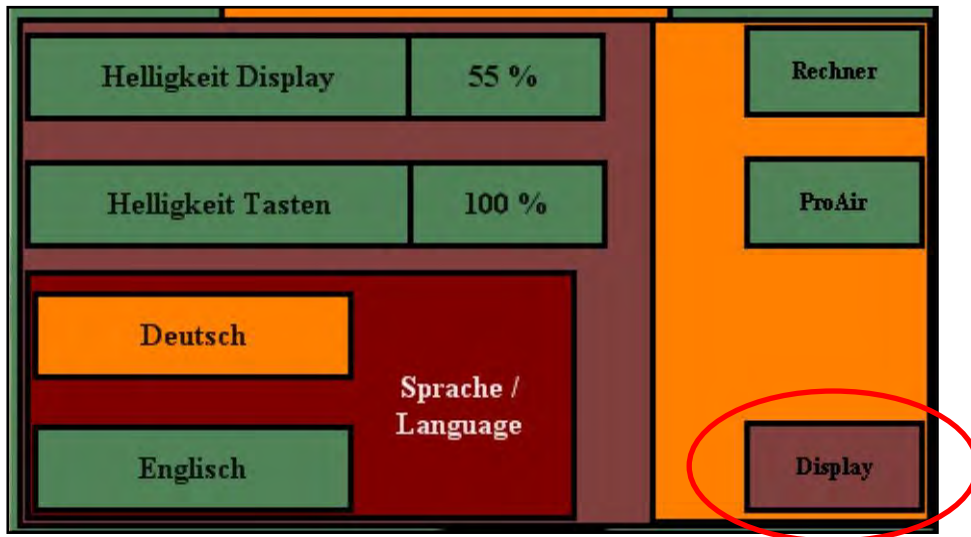

Close the submenu by pressing <ESC>.

8.5. Error Messages

8.5.1. Compressor Temperature

Excessive compressor temperature is signaled by a red warning; the compressor is disabled simultaneously.

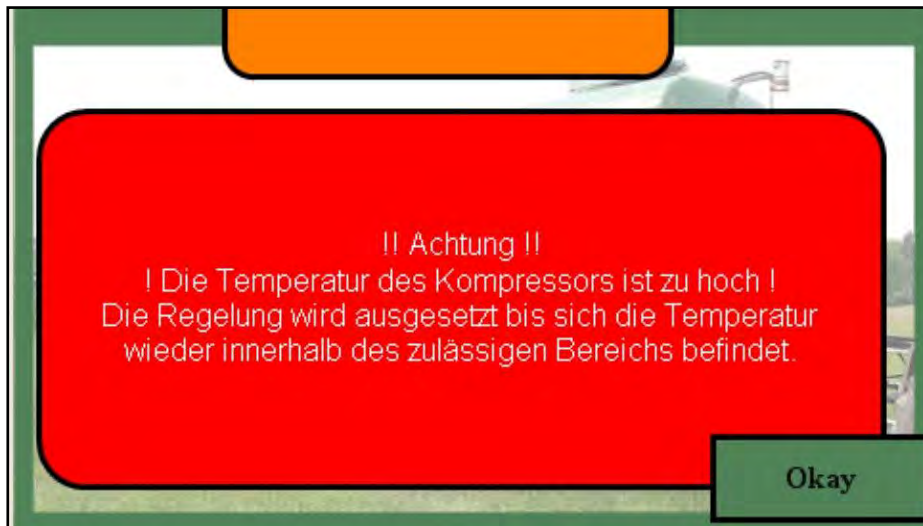

Before continuing, this message must be acknowledged by pressing **<F8>**. As long as the temperature of the compressor has not been corrected, a flashing „tire“ symbol appears on the screen.

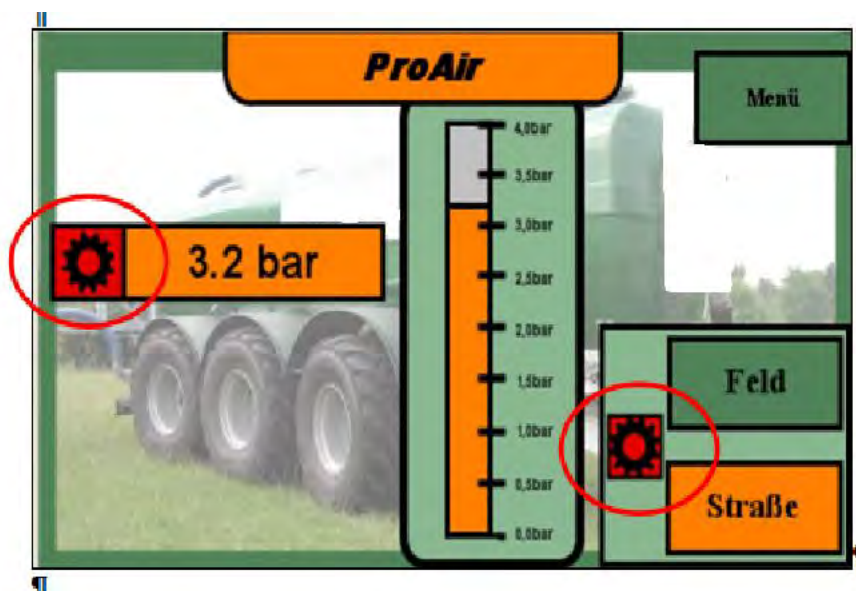

8.5.2. CAN Error

Communication between control modules is carried out by CAN-Bus (Controller Area Network). As interruption of data transfer may entail data loss and irregular system reactions, a message appears, which request the user to restart the control.

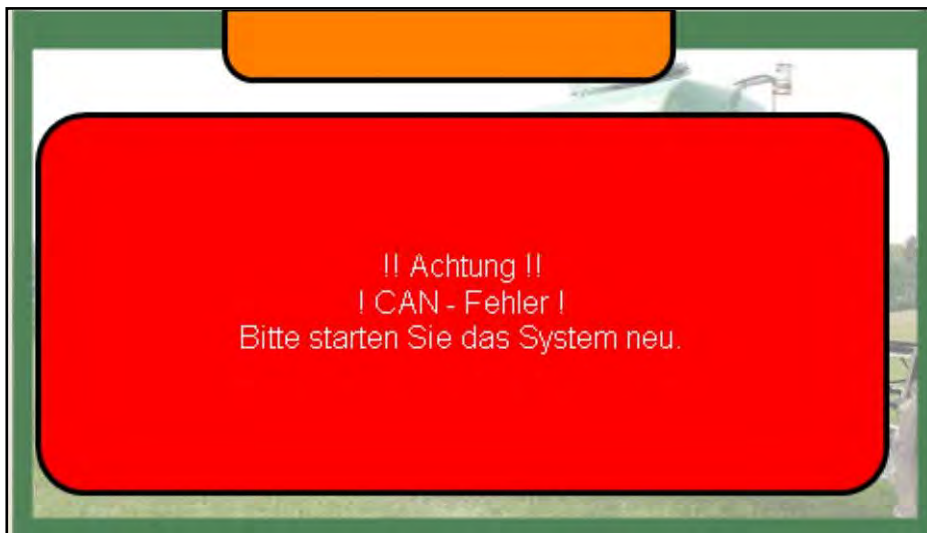

For restart, the power connection of all system components must be separated. This state has to be maintained for at least 10 seconds.

8.6. IFM-Display – Control Loop Settings

8.6.1. 1st Control Loop

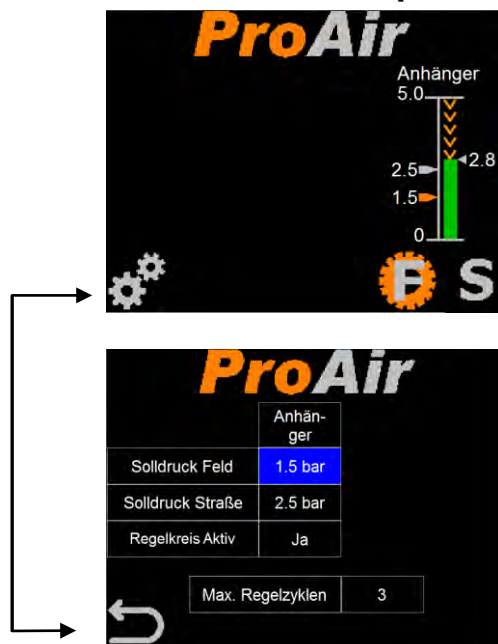

8.6.2 2nd Control Loop

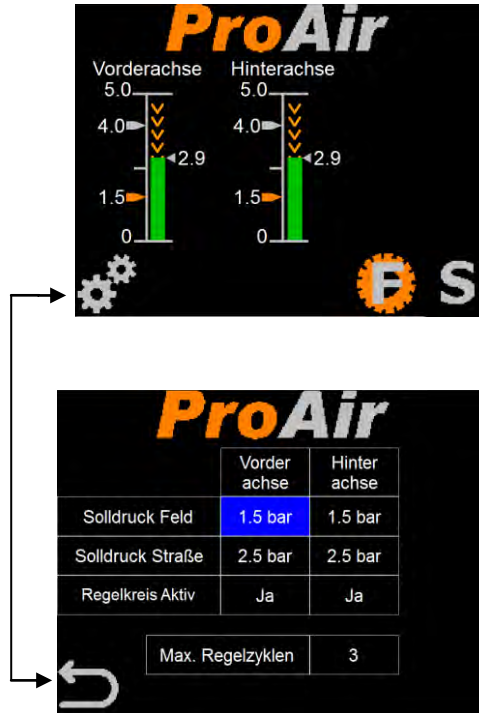

8.6.3 3rd Control Loop

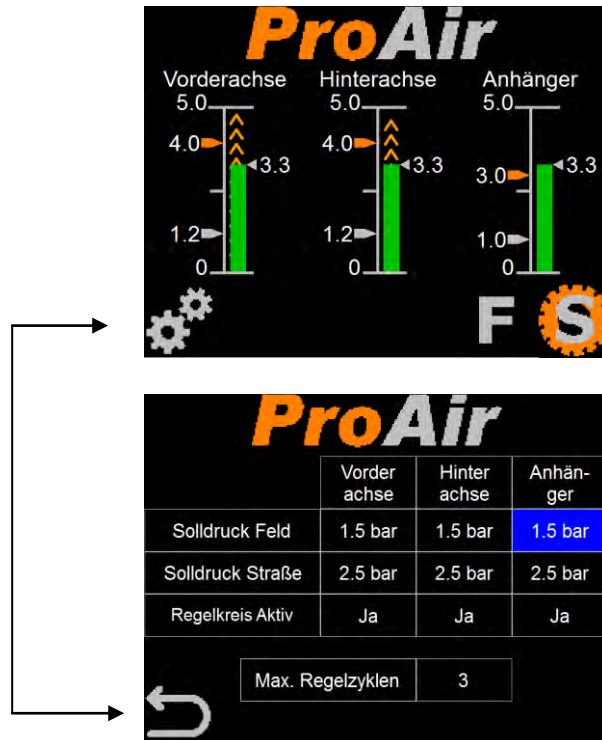

8.6.4 System Parameters

	Vorderachse	Hinterachse	Anhänger
Aufpumpzuschlag	0.20 bar	0.20 bar	0.20 bar
Ablasszuschlag	0.15 bar	0.15 bar	0.15 bar
Zul. Druckabweich.	0.15 bar	0.15 bar	0.15 bar
Abschalttol. erhöh.	0.15 bar	0.15 bar	0.15 bar
Abschalttol. verr.	0.15 bar	0.15 bar	0.15 bar

↩ 1/4



	Vorderachse	Hinterachse	Anhänger
Mul.-Faktor erhöh.	100 %	100 %	100 %
Mul.-Faktor verr.	100 %	100 %	100 %
Sperventil vorh.	Nein	Nein	Nein

↩ 2/4



	Kompr.
Pneu. Vorschalt	Ja
Vorlauf Kompr.	10 s
Nachlauf Kompr.	50 s

Firmenlogo ProAir

↩ 4/4

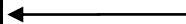

	Vorderachse	Hinterachse	Anhänger
Kreis Vorhanden	Ja	Ja	Ja
Min. Soll-Druck	1.0 bar	1.0 bar	1.0 bar
Max. Soll-Druck	4.0 bar	4.0 bar	4.0 bar
Min Ist-Druck	0.5 bar	0.5 bar	0.5 bar
Max Ist-Druck	4.5 bar	4.5 bar	4.5 bar

↩ 3/4

8.7. Connection Plans

8.7.1 Pinout CR0403

as from 06/27/2016

The Basic Controller represents the core in the PLC network. The configuration is established by means of AMP-Standard-Timer Connectors. Never modify the following configuration, otherwise the function of the control may be impaired.

A	B	C	D	E	F	N2	P/N1
8-polig						4-polig	6-polig
VBB _S	VBB _S	VBB _S	OUT0	OUT4	OUT8	VBB _S	VBB _S
IN0	IN4	IN8	GND	GND	GND	GND	VBB ₁
IN1	IN5	IN9	OUT1	OUT5	OUT9	CAN2_H	VBB ₂
GND	GND	GND	GND	GND	GND	CAN2_L	GND
GND	GND	GND	OUT2	OUT6	OUT10		CAN1_H
IN2	IN6	IN10	GND	GND	GND		CAN1_L
IN3	IN7	IN11	OUT3	OUT7	OUT11		
VBB _S	VBB _S	VBB _S	GND	GND	GND		

Sensors and actuators have to be connected as prescribed by the corresponding specifications. Signal lines have to be wired to the following contacts:

<p>IN0: Sensor Tire pressure (0 – 10 V) Trailer / Semitrailer</p> <p>IN1: Sensor Tire pressure, Rear axle (0-10V)</p> <p>IN2: Sensor Tire pressure, Front axle (0-10V)</p> <p>IN3: Sensor Angle transmitter (4...20mA)</p> <p>IN5: Tire pressure compressor Temperature Emergency Stop</p>	<p>OUT0: Valve filling Trailer / Semitrailer</p> <p>OUT1: Valve filling Rear axle</p> <p>OUT2: Valve filling Front axle</p> <p>OUT3: Valve releasing Trailer / Semitrailer</p> <p>OUT8: Valve releasing Rear axle</p> <p>OUT9: Valve releasing Front axle</p> <p>OUT10 : Switch ON compressor/ Hydraulic valve</p> <p>OUT11: Pneumatic circuit/ Open outlet valve</p>
---	---

CAN 2 H → Display Communication
 CAN 2 L → Display Communication

8.7.2 Pinout OPUS A3

The display has to be connected as follows:

PIN	
1	VCC
2	Ignition Input
3	GND
4	CarGND
5	n. c.
6	n. c.
7	n. c.
8	CAN1H
9	CAN1L

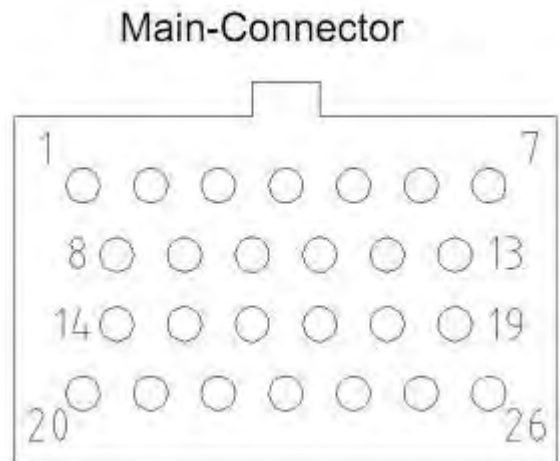

8.8 Connection Plan IFM Display

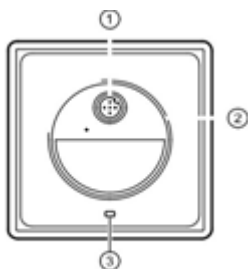

- 1: M12-Connector
- 2: M52-Thread for fastening nut
- 3: Twist protection

M12-Connector, A coded, 5 pin

Supply, CAN

Versorgung, CAN	
1	n.c.
2	8...32 V DC
3	GND
4	CAN_H
5	CAN_L

9 Spare Parts NK 60

9.1 Case

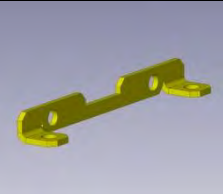

Pos.		Q'ty	Designation	Article no.
1		1	Coupling	2000-00040-005
2		1	Engine support	2000-00040-006
3		1	Compressor bracket	03735-003
4		2	Protection bracket	03735-004

5		1	Frame	03735-100
6		1	Case Sheet	03735-201
7		1	Bottom Sheet	03735-202
8		1	Rear Sheet	03735-203
9		1	Cover with Screen	03735-204
10		1	Outer Cooler Support	03735-206
11		1	Inner Cooler Support	03735-207
12		1	Case Sheet	03735-210
13		1	Cooler Support	03735-212
14		1	Ventilator Support	03735-213
15		1	Ventilator Cover	03735-214

17		4	Hood Retainer, Large	901300
18		(4)	Rubber for Hood Retainer, Large	901301
19		20	ISO 4018 – M5 x 10-WN	
20		2	ISO 4017 – M5 x 12-N	
21		3	ISO 4017 – M5 x 25-N	
22		4	ISO 4018 – M6 x 16-WN	
23		7	ISO 4017 – M8 x 16-N	
24		21	ISO 4017 – M8 x 25-N	
25		2	ISO 4015 – M8 x 65 x 22-N	
26		19	ISO 4018 – M10 x 20-WN	
26a	optional for attachment of pos.9	8	ISO 4018 – M10 x 20 – 8.8	
27		2	ISO 4017 – M10 x 25-N	
28		2	ISO 4017 – M10 x 30-N	
29		4	ISO 4018 – M10 x 30-WN	
30		20	ISO 4032 – M5 – W - N	
31		4	ISO 4032 – M6 – W - N	
32		20	ISO 4032 – M8 – W - N	
33		25	ISO 4032 – M10 – W - N	

8.6. Compressor/Control





Pos.		Q'ty	Designation	Article no.
1		1	Cooler (4 - 5,5 kW)	
2		1	Pneumatic Valve- MV1414	MV1414
3		3	Hydraulics (Bracket)	
4		1	Ventilator (Type OK920)	9202430N
5		1	Compressor	NK60-V004
6		1	Hydraulic Engine Bucher	32-016

7		1	Temperature Display	
8			Oil Filter	102979
9			Separator Cartridge	85483
10		1	Air Filter	100771
11		1	Pressure Sensor	
12		2	Connecting Hose Cooler	
13		1	Connecting Hose Compressor	
14		1	PLC Control IFM-Basic-Controller CR0403	403
15		1	Display	
16		1	Connecting Cable Display ↔ Control	

10. Spare Parts EVO 3

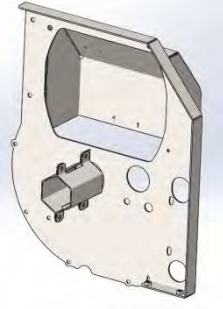
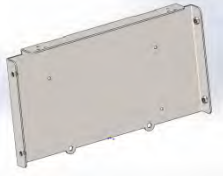
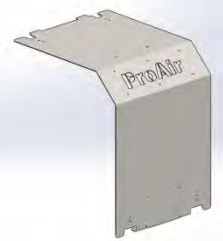

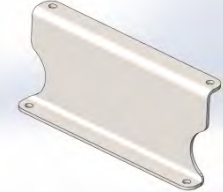
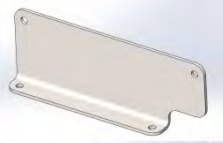

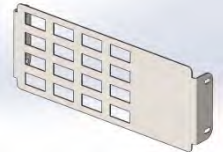
10.1 Case



Pos.		Q'ty	Designation	Article no.
1		1	Compressor Bracket	2000-00136-003
2		1	Coupling	2000-00136-005
3		1	Engine Support	2000-00136-006
4		2	Frame	2000-00136-100
5		1	Case Sheet Left Side	2000-00136-210

6		1	Case Sheet Right Side	2000-00136-220
7		1	Rear Sheet	2000-00136-230
8		1	Hood	2000-00136-241
9		1	Reinforcement	2000-00136-243
10		1	Bottom Sheet	2000-00136-250
11		1	Cooler Bracket	2000-00136-261
12		1	Cooler Bracket	2000-00136-262
13		1	Cover	2000-00136-263
14		1	Ventilation Plate	2000-0136-270

15		1	Tube Assembly	2000-00136-300
16		4	Hood Retainer, Large	901300
17		(4)	Rubber for Hood Retainer, Large	901301
18		1	Switch Cabinet	156925
20		18	ISO 4017 – M5 x 12-N	
21			ISO 4017 – M5 x 25-N	
22			ISO 4018 – M6 x 16-WN	
23		2	ISO 4017 – M8 x 16-N	
24		21	ISO 4017 – M8 x 25-N	
25			ISO 4015 – M8 x 65-N	
26			ISO 4018 – M10 x 20 – 8.8	
27		2	ISO 4017 – M10 x 25-N	
28		4	ISO 4017 – M10 x 30-N	
30		20	ISO 4032 – M5 – W – N	
31		4	ISO 4032 – M6 – W – N	
32		20	ISO 4032 – M8 – W – N	
33		6	ISO 4032 – M10 – W – N	

10.2 Compressor/Control



Pos.		Q'ty	Designation	Article no.
1		1	Cooler (4 - 5,5 kW)	TT06G04
2		1	Pneumatic Valve - MV1414	MV1414
3		3	Elbow 1"	
4		1	Compressor	EVO 3
5		1	Hydraulic Engine	M12
6		1	Temperature Display	
7			Oil Filter	N32047
8			Separator Cartridge	84585
9		1	Air Filter	N37236
10		1	Pressure Sensor	
11		2	Connecting Hose Cooler	
12		1	Connecting Hose Compressor	

13		1	PLC - Control IFM-Basic-Controller CR0403	403
14		1	Display	
15		1	Connecting Cable Display ↔ Control	

11. Spare Parts EVO6



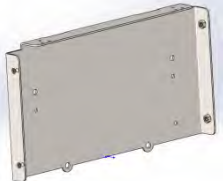



11.1 Case

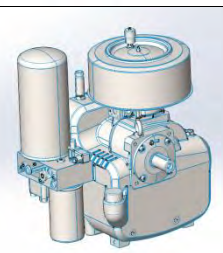

Pos.		Q'ty	Designation	Article no.
1		1	Compressor Bracket	2000-00105-003
2		1	Coupling	2000-00105-005
3		1	Engine Support	2000-00105-006
4		2	Frame	2000-00105-100
5		1	Case Sheet Left Side	2000-00105-210

6		1	Case Sheet Right Side	2000-00105-220
7		1	Rear Sheet	2000-00105-230
8		1	Hood	2000-00105-241
9		1	Reinforcement	2000-00105-243
10		1	Bottom Sheet	2000-00105-250
11		1	Cooler Bracket	2000-00105-261
12		1	Cooler Bracket	2000-00105-262
13		1	Cover	2000-00105-263
14		1	Ventilation Plate	2000-0105-270

15		1	Tube Assembly	2000-00105-300
16		4	Hood Retainer, Large	901300
17		(4)	Rubber for Hood Retainer, Large	901301
18		1	Switch Cabinet	156925
20		18	ISO 4017 – M5 x 12-N	
21			ISO 4017 – M5 x 25-N	
22			ISO 4018 – M6 x 16-WN	
23		2	ISO 4017 – M8 x 16-N	
24		21	ISO 4017 – M8 x 25-N	
25			ISO 4015 – M8 x 65-N	
26			ISO 4018 – M10 x 20 – 8.8	
27		2	ISO 4017 – M10 x 25-N	
28		4	ISO 4017 – M10 x 30-N	
30		20	ISO 4032 – M5 – W – N	
31		4	ISO 4032 – M6 – W – N	
32		20	ISO 4032 – M8 – W – N	
33		6	ISO 4032 – M10 – W – N	

11.2 Compressor/Control

Pos.		Q'ty	Designation	Article no.
1		1	Cooler (4 - 5,5 kW)	TT06G04
2		1	Pneumatic Valve - MV1414	MV1414
3		3	Elbow 1"	
4		1	Compressor	EVO 6
5		1	Hydraulic Engine	M25
6		1	Temperature Display	
7		1	Oil Filter	100333
8		1	Separator Cartridge	85484
9.1		1	Air Filter until 2016 Pneumatic Intake	100771
9.2		1	Air Filter „Prototype 2016“ Special Case	N18906
9.3		1	Air Filter up from 2016 Electric Intake	N34545
10		1	Pressure Sensor	
11		2	Connecting Hose	

			Cooler	
12		1	Connecting Hose Compressor	
13		1	PLC-Control IFM-Basic-Controller CR0403	403
14		1	Display	
15		1	Connecting Cable Display ↔ Control	

12. Imprint



Buschkamp 13
48324 Sendenhorst

Germany

Phone: (49) 25 35 / 55 198 0
Fax: (49) 25 35 / 55 198 19

E-Mail: info@agrarpro.de
Internet: www.agrarpro.de

13. Appendix

Notes:

